

KITRPLWB & CYLLWB Installation Guide

The Fontaine® LWB slider bracket has several rebuild kits for maintaining an operating fifth wheel slider style mount. Installation instructions have been provided below when installing either KITRPLWB to replace the locking wedges or CYLLWB to replace the air cylinder. These instructions will apply based on the current setup of the LWB bracket that was installed on your specific LWB slider style mount.

PLEASE NOTE if both the locking wedges and air cylinder must be replaced, order and install KITRXLWB (major repair kit).

KITRPLWB Instructions

Before reading the following instructions, please note that these directions **ONLY APPLY** if you are changing out the locking wedges, **AND** have the previous generation air cylinder installed on the LWB bracket linkages (see Figure 1).

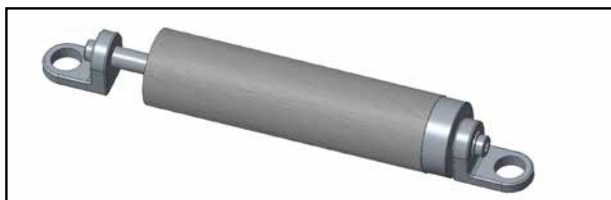

Figure 1: Previous Generation Air Cylinder

If the air cylinder currently installed on your LWB bracket linkages appears like the one above, then both the locking wedges and the linkages will need to be replaced. Otherwise, if the air cylinder **DOES NOT** appear as the one above, simply replace the locking wedges using the supplied hardware and discard the linkages supplied in the kit. The locking wedges provided in this kit will be completely flat, with an offset hole to bolt the new linkage to, as well as a universal locking slot that will function with both previous and current generation LWB brackets. The linkages provided in this kit will also be completely flat (see Figure 2). This will accommodate the locking wedges in the repair kit, as well as the previous generation air cylinder (shown above).

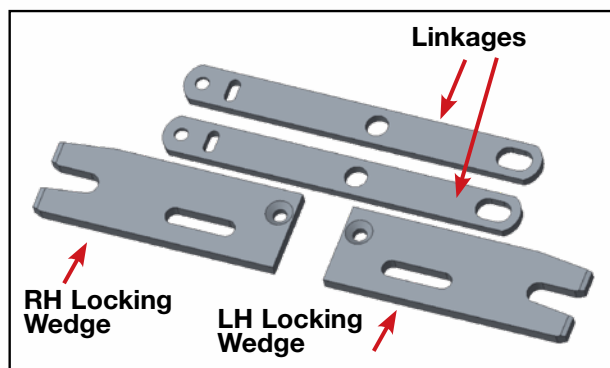

Figure 2: Locking Wedges & Linkages

Removal of Locking Wedges & Linkages

(See Figure 3):

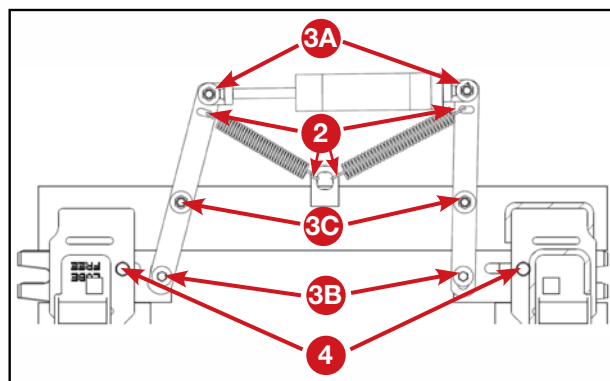

Figure 3: Parts Removal Diagram

1. Remove fifth wheel from the mounting bracket. This includes:
 - a. Removing cotter pins from the retainer pins
 - b. Removing the retainer pins
 - c. Removing the bracket pins from the fifth wheel
 - d. Remove fifth wheel from mounting bracket
2. Remove the springs from both linkages, **2** so that the linkages are free to move.

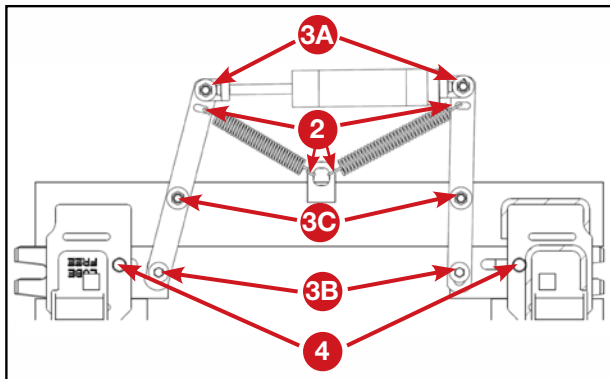

Figure 3: Parts Removal Diagram (Continued)

3. Remove the linkage hardware (nuts, bolt, spacers, and washers).

This includes:

- a. Removing hardware connecting linkages to air cylinder **3A**
- b. Removing hardware connecting linkages to locking wedges **3B**
- c. Removing hardware connecting linkages to bracket **3C**

4. Remove the locking wedges by removing the bolts and lock washers from the riser plate, and afterwards sliding them out of the bracket wedge pockets. **4**

NOTE: Do not discard hardware from Steps 3A, 3C, and 4 above; these will be re-installed.

Installation of New Locking Wedges & Linkages
(See Figure 4):

1. Place the new locking wedges in their respective bracket wedge pockets, so that the wedge slot matches with the tapped hole in the riser plate. **1**

NOTE: The counter-sunk hole should be on the bottom surface, not visible.

- 2. Re-install the bolt and lock washer into the tapped hole in the riser plate (previously removed). **2**
- 3. Install the new linkages using both new and previous hardware).

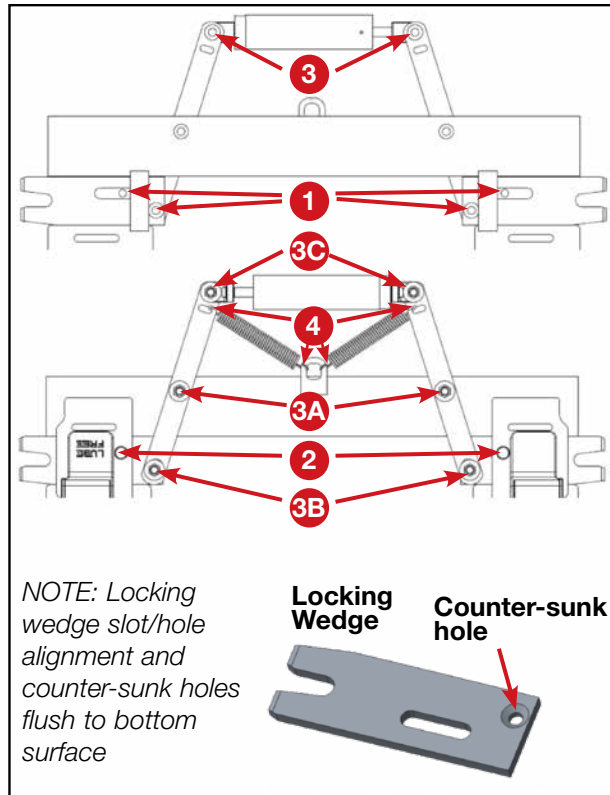

Figure 4: Parts Installation Diagram

This includes:

- a. Installing hardware connecting linkages to bracket (previously removed) **3A**
- b. Installing hardware connecting linkages to locking wedges (new hardware) **3B**
- c. Installing hardware connecting linkages to air cylinder (previously removed) **3C**

NOTE: The counter-sunk hole should be on the bottom surface, not visible.

- 4. Install the new springs onto the bracket and same slots as the previous linkages. **4**
- 5. Re-install the fifth wheel by placing it back on top of the mounting brackets.

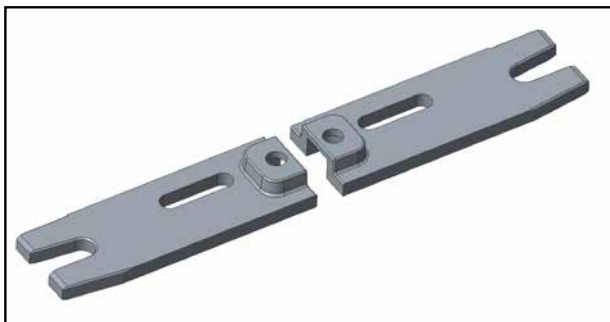

Figure 5: Previous Generation Forged Locking Wedges

CYLLWB Instructions

Before reading the following instructions, please note that these directions **ONLY APPLY** if you are changing out the air cylinder, **AND** have the previous generation forged locking wedges installed in the LWB bracket (see Figure 5).

If the locking wedges currently installed on your LWB bracket appear as those above, then both the air cylinder and the linkages will need to be replaced. Otherwise, if the locking wedges **DO NOT** appear as the ones above, simply replace the air cylinder using the supplied hardware and discard the linkages supplied in the kit. The air cylinder provided with this kit will have bracketed ends to bolt onto the new linkages, which will function with both previous and current generation LWB brackets. The linkages provided in this kit will be bent on both ends (see Figure 6). This will accommodate the air cylinder in the repair kit, as well as the previous generation forged locking wedges (shown above).

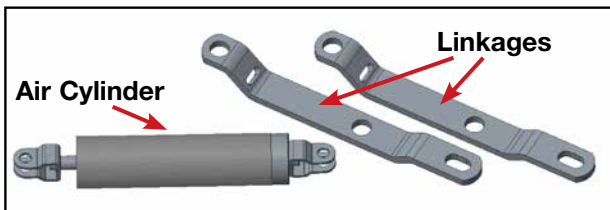

Figure 6: Air Cylinder & Linkages

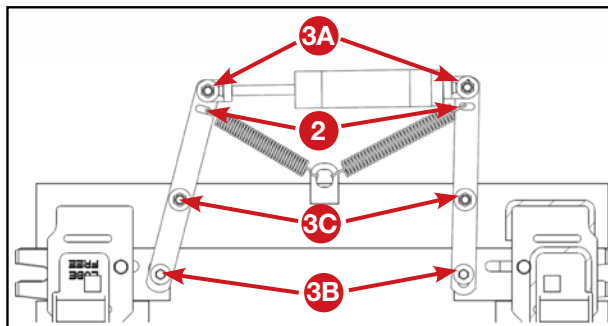

Figure 7: Parts Removal Diagram

Removal of Air Cylinder & Linkages

(See Figure 7):

1. Remove fifth wheel from the mounting bracket.
This includes:
 - a. Removing cotter pins from the retainer pins
 - b. Removing the retainer pins
 - c. Removing the bracket pins from the fifth wheel
 - d. Remove fifth wheel from mounting bracket
2. Remove the springs from both linkages, so that the linkages are free to move. **2**
3. Remove the linkage hardware (nuts, bolt, spacers, and washers).
This includes:
 - a. Removing hardware connecting linkages to air cylinder **3A**
 - b. Removing hardware connecting linkages to locking wedges **3B**
 - c. Removing hardware connecting linkages to bracket **3C**

NOTE: Do not discard hardware from Steps 3B and 3C above; these will be re-installed.

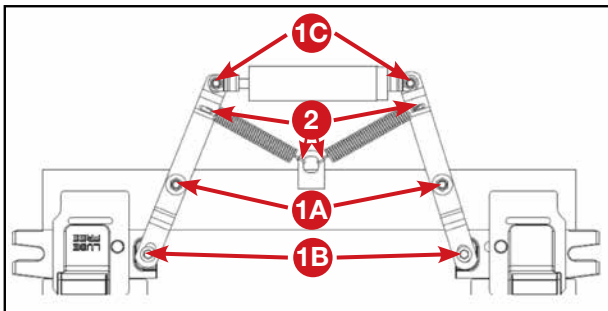

Figure 8: Parts Installation Diagram

Installation of New Air Cylinder & Linkages

(See Figure 8):

1. Install the new linkages using both new and previous hardware.

This includes:

- a. Installing hardware connecting linkages to bracket (previously removed) **1A**
 - b. Installing hardware connecting linkages to locking wedges (previously removed) **1B**
 - c. Installing hardware connecting linkages to air cylinder (new hardware) **1C**
2. Re-install the springs onto the bracket and same slots as the previous linkages. **2**
 3. Re-install the fifth wheel by placing it back on top of the mounting brackets.