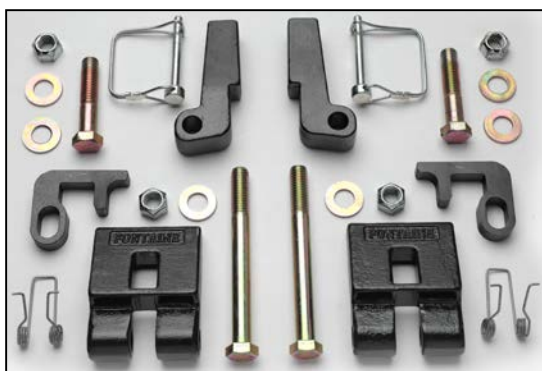
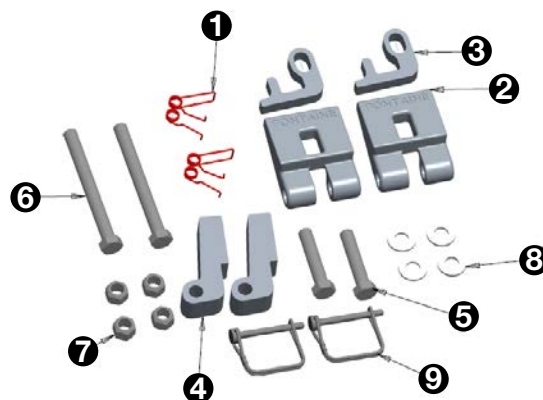


## KIT-NO-TILT Installation Guide

The Fontaine **KIT-NO-TILT** is a bolt on kit that converts no-tilt ready assemblies to a non-articulating fifth wheel. This kit is only intended for assemblies that are equipped with the no-tilt mounting blocks supplied on all HDS (Outboard) and HDI (Inboard) slide assemblies along with PMH and PMX stationary mount fifth wheel assemblies that have been designed to accept the **KIT-NO-TILT** conversion kit. If you have any questions on which assemblies can use the conversion kit, please visit our website [www.fifthwheel.com](http://www.fifthwheel.com), or contact Fontaine Customer Support: [parts@fifthwheel.com](mailto:parts@fifthwheel.com).

The Fontaine No-Tilt Blocking Kit (KIT-NO-TILT) includes the following:

	Parts provided in this kit	QTY
①	Rear Keeper Retention Spring	2
②	Rear Support Block	2
③	Rear Keeper Block	2
④	Front Support Block	2
⑤	Hex Head Bolt ½ x 2.50" (Grade 8)	2
⑥	Hex Head Bolt ½ x 5.00" (Grade 8)	2
⑦	Hex Locknut ½"	4
⑧	Flat Washer ½"	4
⑨	Clevis Pin With Steel Wire-Lock	2



### Aftermarket No-Tilt Kit.

No-Tilt capable mounts can be converted to no-tilt fifth wheels by ordering easy to install kit (part number **KIT-NO-TILT**). Same kit works for HDS, HDI, PMH or PMX mounts.



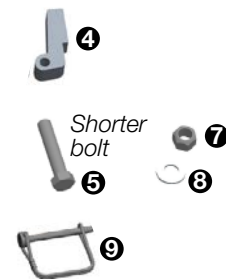
**NO-TILT option for frame dump applications—simply flip the four levers on the mount to block the fifth wheel from rocking**

## KIT-NO-TILT Installation Guide

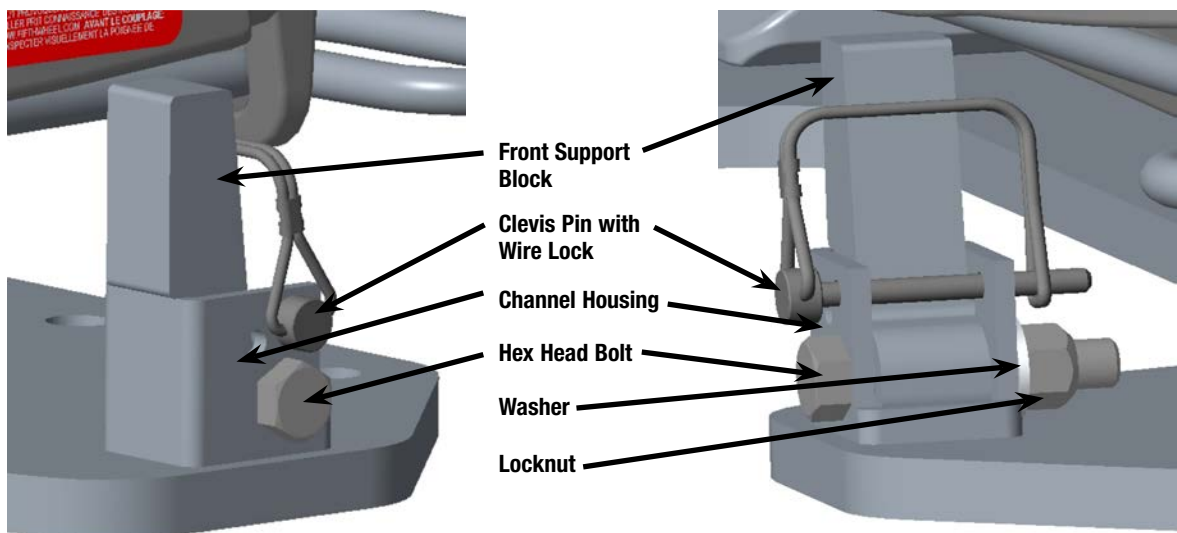
### Installation Instructions

*(Please read the entire instructions before beginning installation).*

1. Insert the front support block (Item 4) into the open end of the welded-on housing. It should be oriented as shown in **Diagram 1**.
2. Insert the 2.50" bolt (Item 5) into the lower hole so that it goes through both the block and the housing, install a washer (Item 8) and locknut (Item 7) as shown in **Diagram 1**. Torque to 65 ft·lbs and make sure the front support block can still rotate freely.
3. Insert the clevis pin (Item 9) as shown in **Diagram 1**.
4. Repeat steps 1-3 for the other front block.

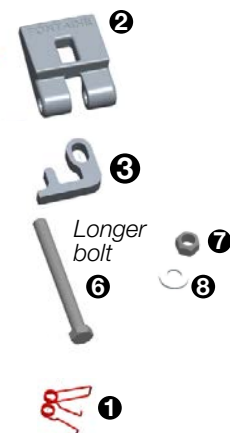


**Diagram 1. Front and Rear Views of the Front Block Assembly**

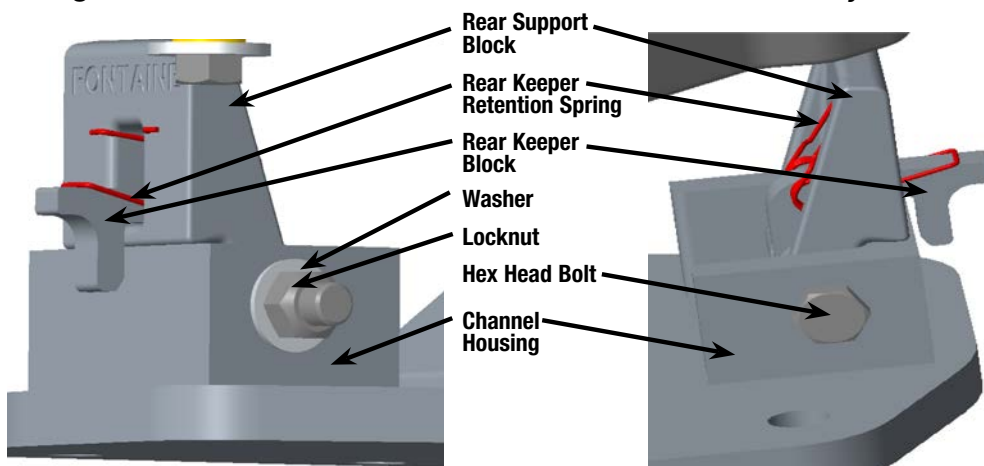


## Installation Instructions (Continued)

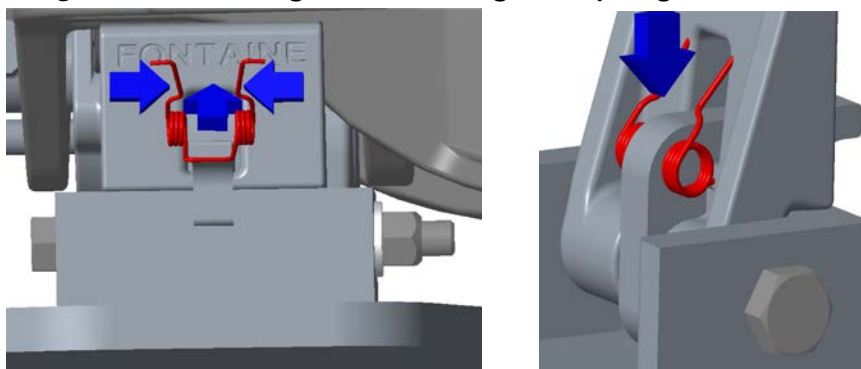
5. Put the rear support block (Item 2) in the channel housing so that the holes align. The cast Fontaine logo should be facing as shown in **Diagram 2**.
6. Insert the rear keeper (Item 3) through the Fontaine faced side of the rear support block. Then, rotate it down to align the slot with the holes in the rear support block.
7. Insert the 5.00" bolt (Item 6) through the assembly and then install a washer and locknut as shown in **Diagram 2**. Torque to 65 ft-lbs and make sure the rear support block can still rotate freely.
8. Insert the rear retention spring (Item 1) by pinching the coils together and pushing the coiled end thru the gap directly under the Fontaine face of the rear support block as shown in **Diagram 3**. Once pushed in far enough, the coils of the spring should drop on each side of the rear keeper as shown in **Diagram 3**.
9. Repeat steps 5-8 for the other rear block.



**Diagram 2. Front and Rear Views of the Rear Block Assembly**

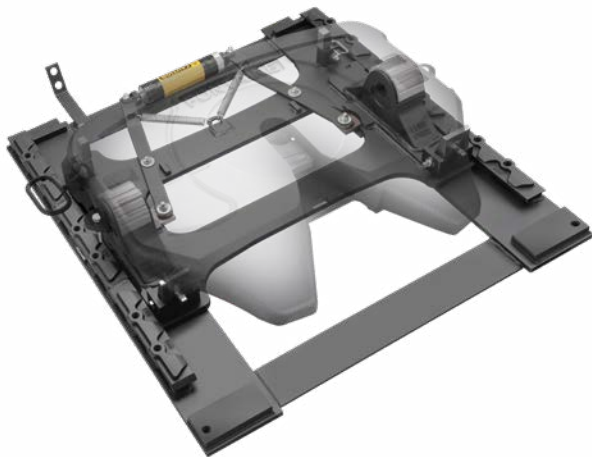


**Diagram 3. Pinching and Inserting the Spring into the Rear Support**

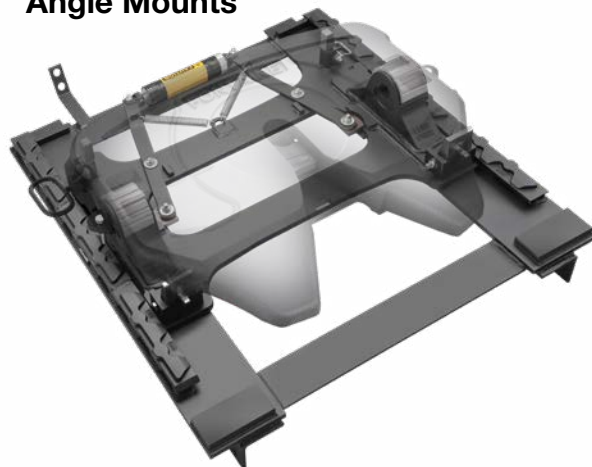


### Current Fifth Wheel No-Tilt Assembly Models

No-Slack® 7000/H7 **HDS**  
Heavy/Severe-Duty Slide  
**Outboard** Mounts



No-Slack® 7000/H7 **HDI**  
Heavy/Severe-Duty Slide **Inboard**  
Angle Mounts



No-Slack® 7000/H7  
**PMH** (37-1/4" bolt centers)  
**PMX** (38" bolt centers)  
Heavy/Severe-Duty **Stationary** Mounts

